

Technical Datasheet clima RO(-rH)

1. Product description

The nova RO room temperature controller is a continuous-action controller for commercial architecture and therefore does not need to be set by the user. The controller has an integrated temperature sensor to detect the room temperature, 2 LEDs for indicating heating, cooling. Additionally the -rH models have an integrated relative humidity sensor.

The device has 4 digital inputs for example light, sun blind, occupancy switches, window contacts or dew point sensors.

It consists of a controller with a heating and cooling sequence for controlling the temperature in rooms where radiators, chilled ceilings or fan coils are used. The controller can be switched to the Comfort, Standby or Economy operating modes via the LON network. It is also possible to select the Heat, Cool, Automatic or Free Night Cooling controller functions. The controller has separate heating and cooling sequences with adjustable PI parameters and set points. Additionally, the controller also has a free night cooling function which works in conjunction with windows or ventilation flaps.

An easy LNS plug-in is available for configuration purposes.



clima RO

(All Pictures show clima RO with frame. The frame is not included in the purchased parts package)

2. Mounting and installation

2.1. Mounting



Electrical devices must be assembled and installed by trained personnel only.

Install the LON room temperature controller in a flush-mount switch socket with a recommended minimum depth of 47mm. The end of the installation tube in the flush box must be sealed to avoid any draught in the tube falsifying the measuring result.

Mounting must be done at representative locations for room temperature measurements in order to have an undisturbed measurement. Direct sunlight and air drafts are to be avoided.

All 55mm spacing switch frames are suitable for this product.



Units of the RO-xx series have openings on the right top front for the service switch and service LED.

Before mounting the unit inside an flush-mount switch socket all cables have to be connected. Afterwards the LON room temperature controller can be inserted into the socket and fixated with screws. The switch cover is put onto the metal ring and fixated by the room temperature cover.

Dimensions

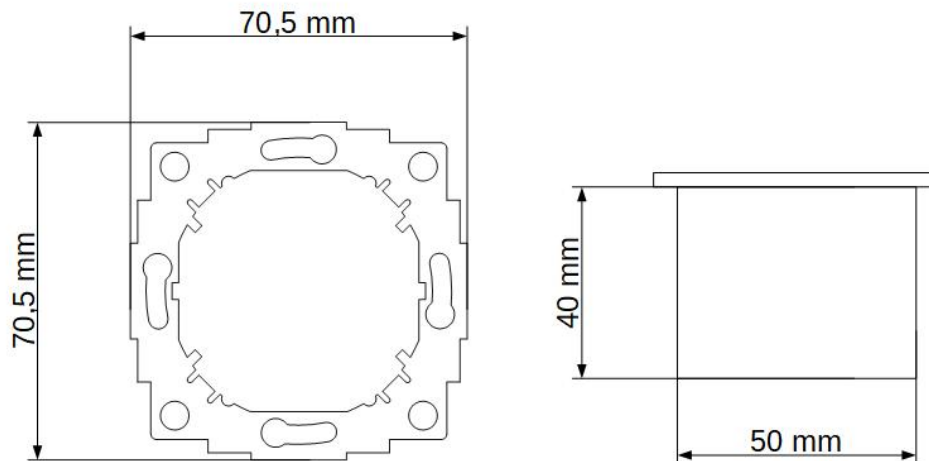

2.1.1 General mounting instructions

In order to ensure the most accurate temperature measurement, the following instructions regarding the installation position should be observed:

The sensor must be positioned in such a way that it detects a wide range of the room climate, but is not directly influenced by the heating or cooling source(s) in the room. For this reason, the room sensor must not be mounted inside shelf walls, in niches, behind curtains or similar covers. Temperature dynamics with other objects in the room and the influence of extraneous heat must be avoided (do not install the room sensor in direct sunlight, near computers, monitors, radiators, lamps, fireplaces, heating or hot water pipes). Also avoid mounting on outside walls and in areas of draught, such as in the immediate nearness of windows and doors. An installation opposite the heat source on an interior wall is the optimum location.

The accuracy of the temperature measurement also depends directly on the temperature dynamics of the wall. The various types of wall (brick, concrete, movable, hollow walls) behave differently to temperature fluctuations. For example, a solid concrete wall perceives the temperature change within a room much more slowly than walls in lightweight construction.

Before installation, additional special features regarding surface and flush mounting should be considered: Living room temperature sensors located inside a flush-mounted box have a longer response time to temperature fluctuations. In extreme cases, they detect the radiant heat of the wall,

even though the air temperature in the room is already lower. The temporally limited deviations are reduced the faster the dynamics (temperature assumption) of the wall is or the longer the query interval of the temperature sensor is selected.

It is also important that with flush-mounted sensors, the flush-mounted box should be completely closed towards the wall so that air circulation can only take place through the openings in the housing cover. Sealing should also be provided between the cable or plastic hose and the installation pipe. Otherwise there will be deviations in the temperature measurement due to uncontrolled air flows. The ventilation slots on the front of the sensor must not be covered or glued.

To avoid condensation, the permissible relative humidity of max. 95% should not be exceeded.

The recommended installation height is approx. 1.5 m above the floor. The room sensor should also be mounted at least 0.5 m from the nearest wall.

2.2. Installation

2.2.1 Layout of the connectors

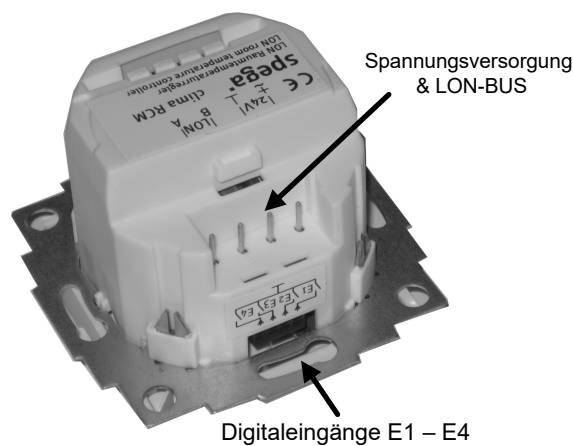

figure 1

2.2.2 power supply and LON connections

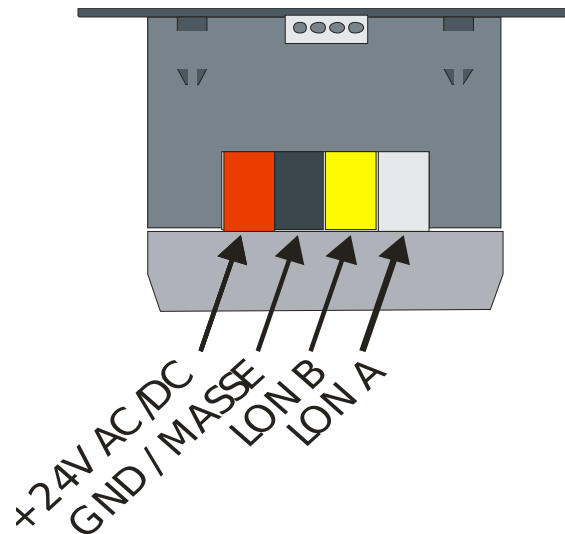

figure 2

Connection	function	type
+ ~	power supply typ. +24V DC / AC	power supply
GND	ground	power supply
A	LON A	LON bus connection
B	LON B	LON bus connection

2.2.3 digital inputs E1 - E4

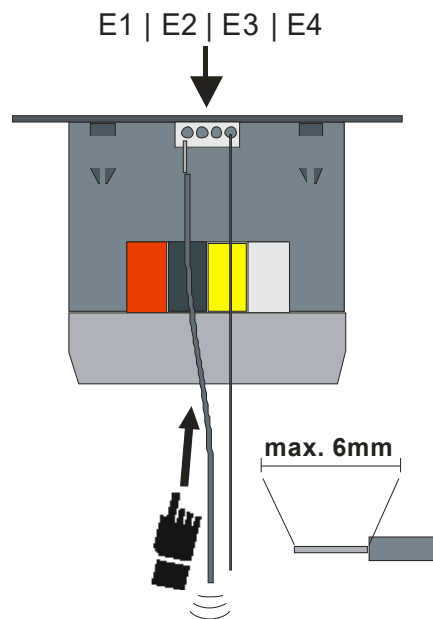
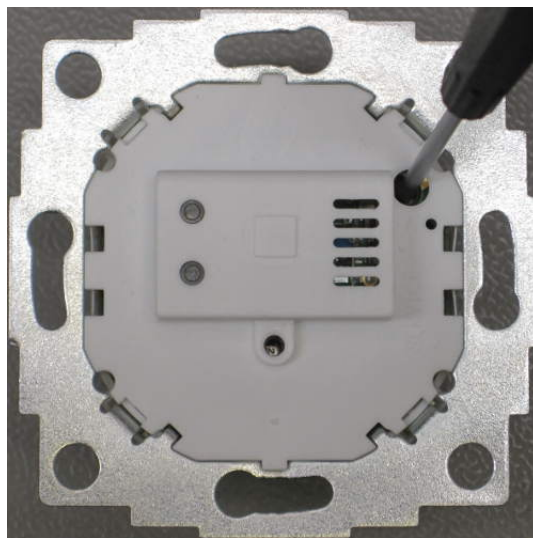
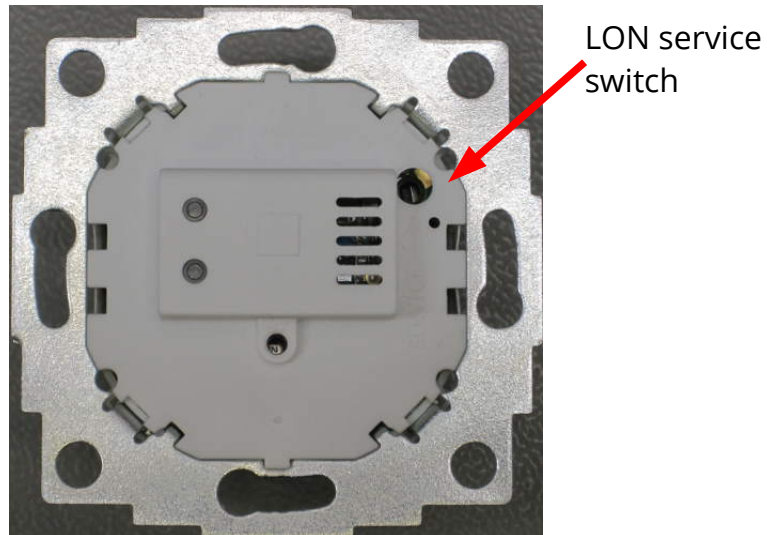

figure 3

connection	function	type
E1	digital input 1	input
E2	digital input 2	input
E3	digital input 3	input
E4	digital input 4	input

1.1.4 LON Service switch

The LON service switch is only accessible when the cover is not mounted. You can operate it using a small screw driver. To the lower right the service LED can be seen. See the picture below:



Service switch operation with screw driver

2.3. Connection example

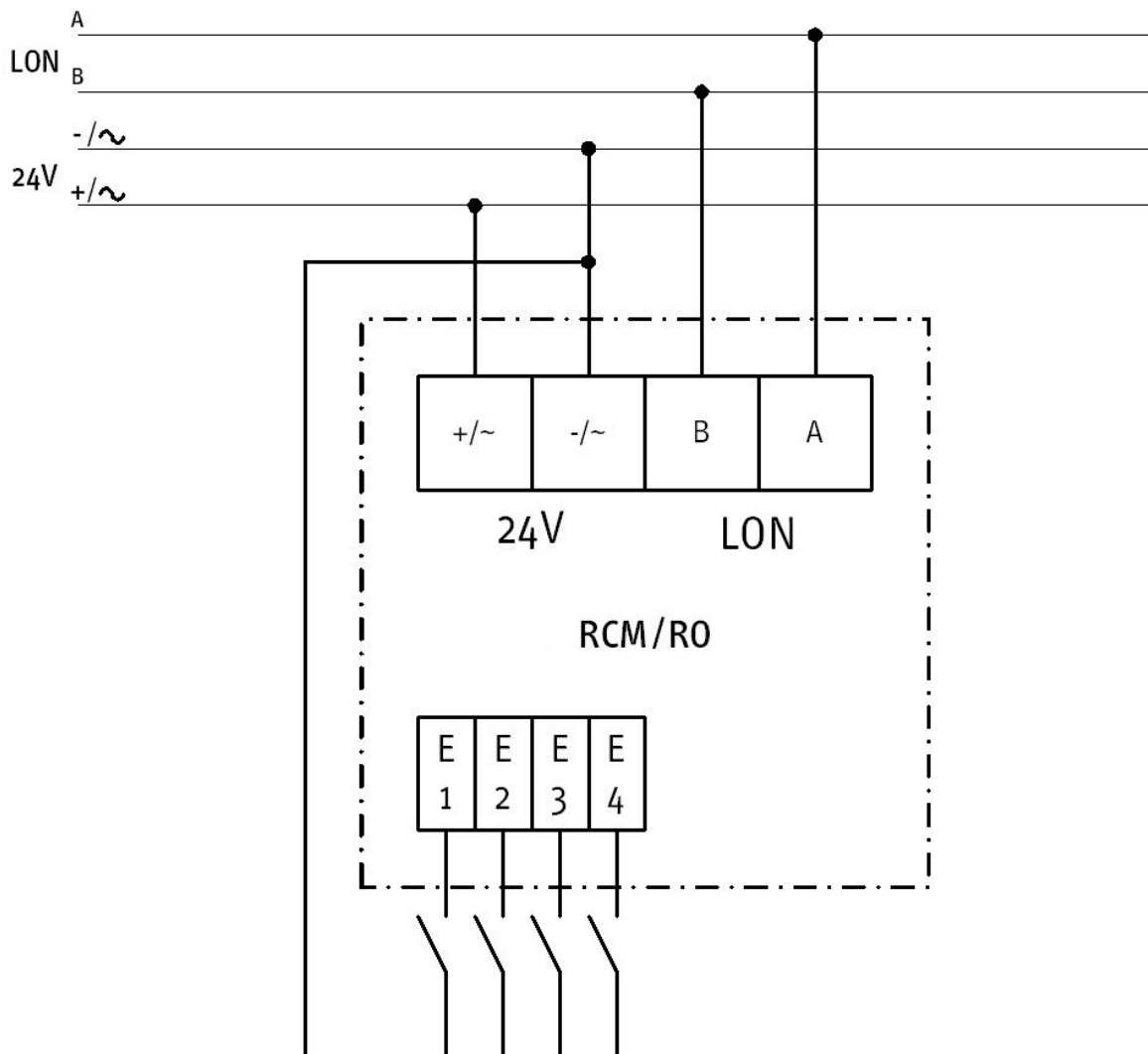

3. Room temperature control with control units of the clima RCM/RO series

The aim of room automation is to control the ambient conditions (e.g. brightness, temperature or air quality) in an occupied room in such a way that people feel comfortable. This subjective feeling is significantly influenced by the environment and is based on the standards for a healthy life, especially with regard to the body's heat balance.

In this application note, the room temperature control with control units of the spega clima RCM/RO series will be examined more closely.

3.1. Definitions

3.1.1 Room temperature

The room temperature is also the quantity that humans perceive with their temperature sensation. The term room temperature should generally not be confused with room air temperature. The room air temperature is only a part of a sum that defines the room temperature.

Room temperature is the sum of the components of thermal radiation from the surrounding surfaces (walls, floor, ceiling, windows) and objects in the room, and the room air temperature.

The human perception of these variables occurs in approximately equal parts:

$$T_R = 0,5 (T_L + T_S)$$

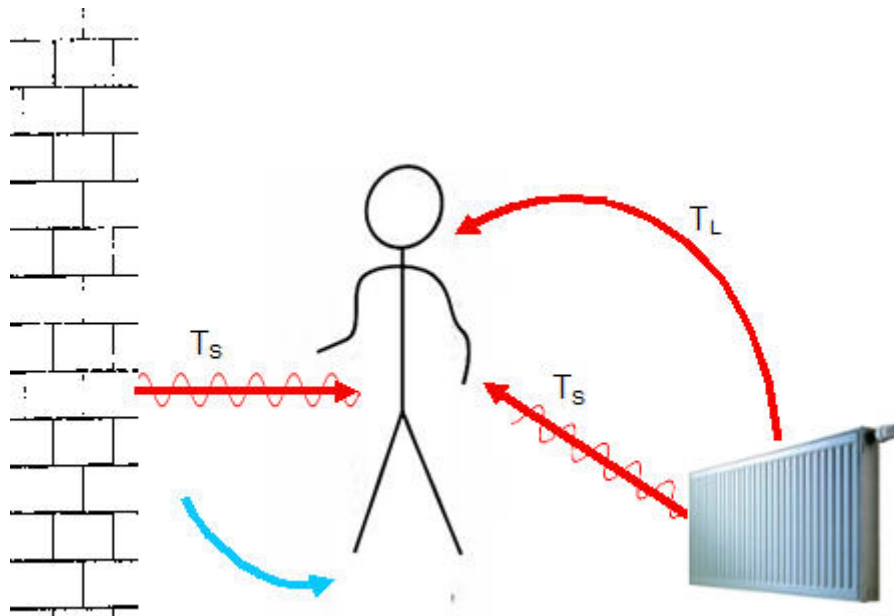

Figure 1: Room temperature is composed of heat radiation and air temperature

3.1.2 Thermal comfort

Thermal comfort is a subjective perception of a room temperature at which a person feels comfortable. The human sensation of warmth plays a role here, which essentially depends on the thermal balance of the human body and a person's expectations of a certain ambient climate in a room. Of course, a person's physical activity and clothing have a direct influence on his or her sensation of warmth.

For a room to be thermally comfortable, the room temperature must be adjusted as a whole, i.e. in balance with physical activity, clothing, indoor air temperature and surface temperatures of the surfaces surrounding the

room. Draughts and heat dissipation through floor surfaces also influence the thermal comfort in a room.

For example, a person feels uncomfortable in a room if, despite a sufficiently high room air temperature, the walls or ceiling surrounding are cold compared to the room air temperature ($\Delta > 3\text{-}5\text{K}$). The component of heat radiation from the wall or ceiling is missing - a subjective feeling of heat withdrawal is created.

Therefore, in order to meet the criterion of subjective thermal comfort, a room must have a sufficiently high air temperature and sufficiently warm walls. Draughts have a negative effect on thermal comfort. This aspect is not considered in this application note, as the room control units of the clima RCM/RO series have no influence on this. Therefore, the room user must ensure, either manually or by other means (e.g. ventilation systems), that no draughts occur which would have a negative effect on thermal comfort.

3.2. Room temperature control with regard to thermal comfort

In the previous definitions, it has become clear that air temperature alone is not sufficient to ensure thermal comfort in a room. Rather, the influence of thermal radiation from the wall must be considered. Due to their high thermal capacity, walls have much greater time constants in the heating curves than the air in the room.

Provided there is a corresponding heating/cooling capacity, it is possible to heat the room air temperature within a short time (minutes to a few hours depending on the room volume). However, wall and surface temperatures change their temperature only very slowly (hours to days, depending on the surface, wall structure and heat loss) due to their high heat capacity.

From an energy point of view, it makes sense to regulate the heating and cooling equipment in a room as required, depending on the occupancy or time of day. An occupied room (energy level = comfort) can have a different, deviating setpoint temperature than an unoccupied room (energy level = standby) or during night setback (energy level = economy). When the post-decrease phase ends or the occupancy status of the room changes, the system switches between the different energy levels - and thus between setpoints.

However, time constants for cooling or heating the room temperature must be taken into account so that a state of thermal comfort is achieved for the room user in good time. Therefore, a surface temperature of walls with a high heat capacity should not fall below a temperature value of less than three Kelvin below the comfort setpoint temperature of the room air. In principle, this applies to all types of walls, but especially to walls in solid construction with high heat capacities.

A room temperature controller should therefore not only control according to the air temperature, but also take the wall temperature into account and include it in the control.

3.3. Room temperature control with the clima RCM/RO

3.3.1 Installation position in the wall and variables influencing the temperature measurement

Room control units of the clima RCM/RO series are mounted in the wall. Room air is supplied to the temperature sensor via ventilation slots in the event of convection.

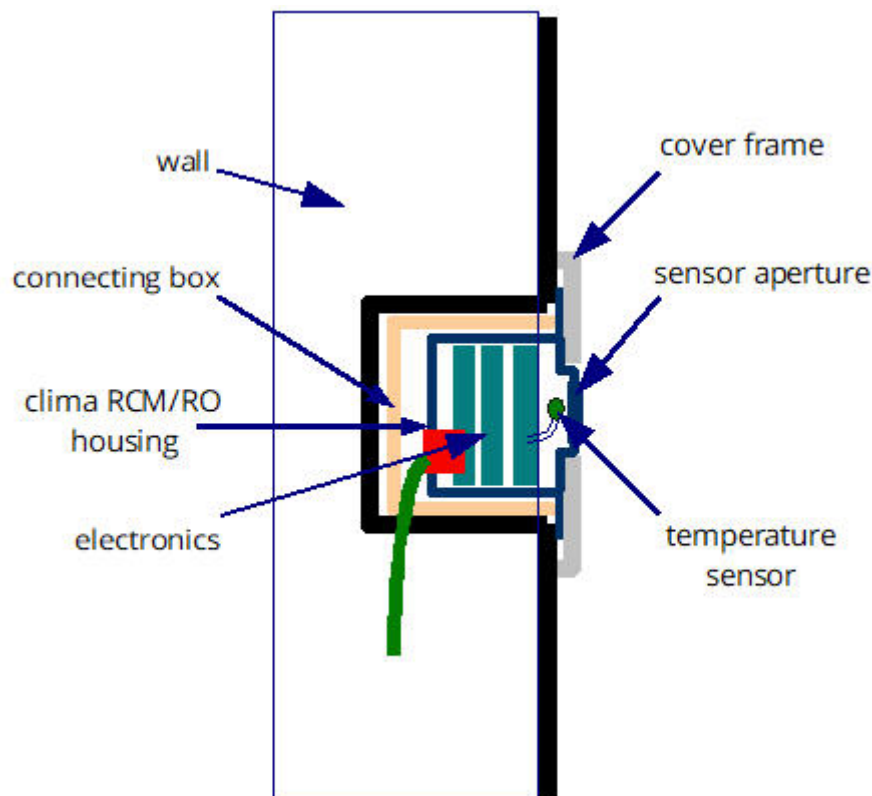

Figure 2: Installation principle of a clima RO control unit in a wall

The measuring principle is illustrated by a heating phase:

When the heating is active, the air in the room is warmed up and air convection occurs, in which air masses flow past the front cover of the clima RCM/RO. This causes turbulence in the sensor chamber of the clima RCM/RO where the temperature sensor is located. This results in an exchange of air. Heated room air flushes around the sensor and is measured. The sensor also registers heat radiation from opposite walls, objects and people in the direction of the room. The influence of the heat radiation decreases with increasing distance of the radiation source from the sensor.

The clima RCM/RO is recessed into the wall. The wall also has a temperature. As a result, heat radiation from the wall is also registered by the sensor. The self-heating caused by the built-in electronics in the control unit is calibrated at the factory and then no longer plays a role in the temperature measurement.

In a room with an active heating system, the clima RCM/RO series room control units register three components of room temperature:

- Room air temperature due to air circulation system used
- Heat radiation of the environment
- Heat radiation of the wall

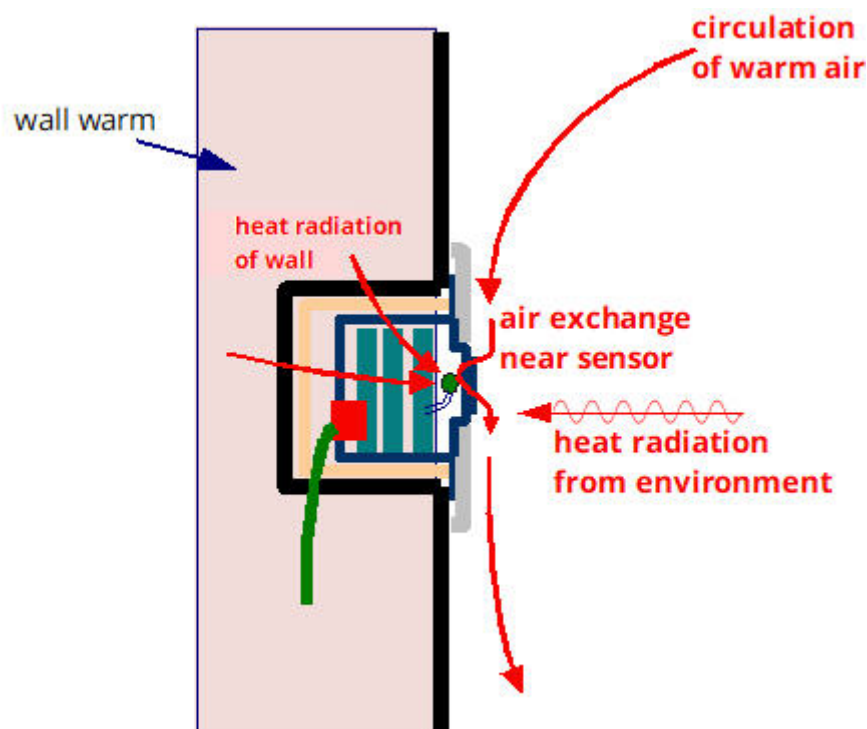

Figure 3: Sensor registers heat radiation and room air temperature with convection

If the heating is not active because the control system reduces the supplied heating power after the setpoint temperature has been reached or the room temperature is to be lowered, the air masses come to a virtual standstill. There is significantly less air circulation. As a result, the component of the air temperature has only a minor influence, since only a small amount of room air exchange takes place at the sensor. The components of the heat radiation from the environment and the wall, however, remain and are registered by the sensor.

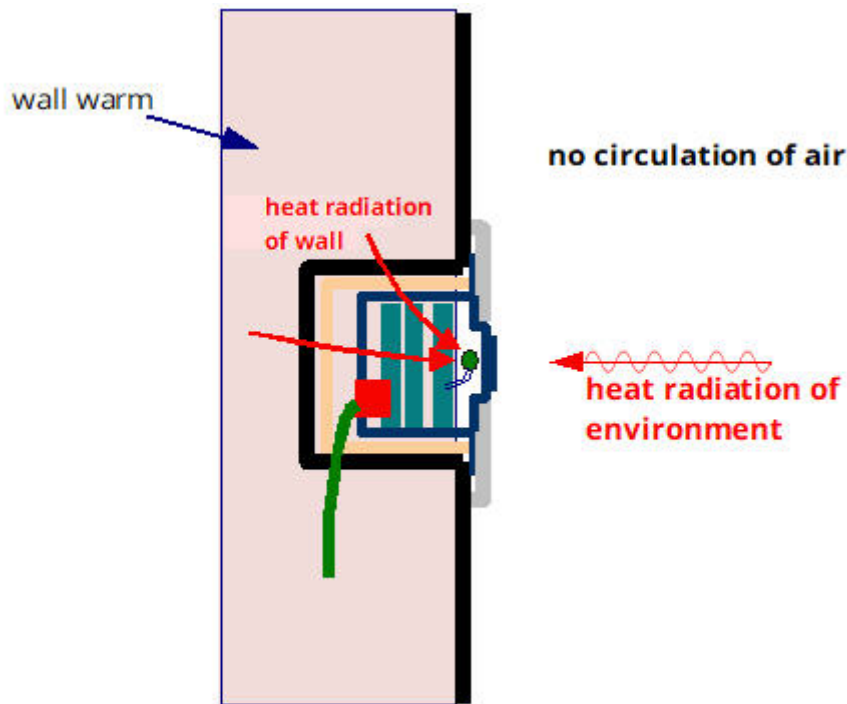

Figure 4: Sensor registers only heat radiation

In the case of no measurable air circulation, the proportion of radiant heat takes on a higher significance in room temperature control.

Due to the high heat capacity of the wall, the wall temperature will change only slowly - in contrast to the air temperature. The air temperature will fall much faster than the temperature of the wall. However, it can also be quickly heated up to a higher setpoint temperature. If the room air temperature is now regulated to a very low setpoint, it is possible that during a long setback period the wall will cool down to such an extent that when the room is occupied again, the heating system cannot manage to regulate the room temperature to a comfortable level in time. The radiant heat of the wall necessary for thermal comfort is then missing.

Therefore, it is important to avoid that the wall cools down in such a way that it is not possible to regulate the room temperature to a comfort value in time. In this case, it makes sense to monitor and control the wall temperature so that it does not fall below a minimum temperature.

Of course, the air temperature should not drop too far, otherwise the room will be perceived as cold when you enter it, which can contradict people's expectations for this room. The consequence is that he/she feels uncomfortable at the first moment.

However, room air temperature and wall temperature are directly related if air convection fails. The air is kept warm by the radiant heat of the wall and the objects in the room as long as sufficient thermal energy is stored in the wall.

For this reason, the room air temperature drops in the same way as the wall temperature if there are no other significant heat sources in the room. To prevent the room air temperature from falling below a certain set point T_L , it must be ensured that the wall temperature does not fall below a certain set point T_W . Tests have confirmed that the difference between $T_W - T_L$ is almost constant when the air circulation movement has subsided.

When the room is heated up again, the air circulation is spontaneously restored and the temperature sensor is flushed with room air. The setpoint value of the room temperature is quickly reached again because the walls as heat sources had not cooled down much. There is no loss of thermal comfort in the room. The following example makes this clear once again.

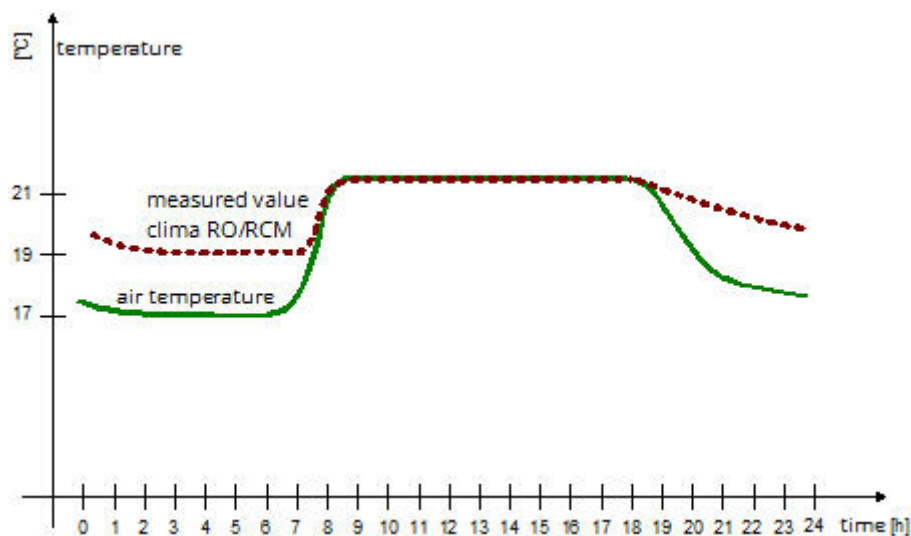

Figure 5: Temperature delta at failed convection is identical - correct measurement of room air temperature at convection

Figure 5 shows that at about 7.00 a.m. the energy level switches to comfort. The heating system heats up to a set point of approx. 21.5°C. The room air temperature rises rapidly, as a warm air cylinder convects in the room. You can clearly see that the clima RCM/RO correctly measures the room air temperature in this phase. The curves are on top of each other. At about 18.00h the energy level is switched back to economy - setpoint 17°C. The room air cools down again quite quickly, the wall is significantly delayed due to its higher heat capacity. The heat radiation of the enclosure surfaces receives a greater weighting during the cooling phase when the measured values are recorded. This makes sense because when the comfort energy level is activated, the temperature of the enclosure surfaces should be within the comfort zone.

It can also be seen that in cases where the heating is switched off, the temperature difference of $T_{RO/RCM} - T_L$ is almost constant. It is therefore easy to infer the air temperature from the clima RO/RCM reading. Of course, this only applies in the static case, i.e. when there is virtually no air convection. A measurement of the air temperature near the sensor in the quasi static

cooling phase shows the difference between the measured value of the RO/RCM and the room air temperature.

For low air setpoints for night set-back, correspondingly lower wall temperatures apply.

3.4. Notes on calibrating the RCM/RO series operator interfaces

Since the room temperature should be controlled if the room is occupied by persons, it is recommended that the clima RCM/RO control unit is adjusted in a state that represents the subsequent ambient situation. This means in detail:

The control unit is switched on for approx. 3 hours so that the static thermal state in the unit is set by the self-heating of the electronics, which is calculated by the unit firmware using the factory offset.

Heated walls in the room, especially the wall in which the device is installed, to a level within the comfort zone, but below the comfort target temperature.

During the adjustment, the heating must be switched on (forerun for at least 1h) so that air convection occurs.

If the wall is not heated through, as shown in Figure 6, the radiation component of the wall is missing. A too low temperature is measured and adjusted to the higher room air temperature. Later, when the wall is warmed through, the HMI device indicates a temperature that is too high, since the radiation component of the wall now occurs and is added to the sensor temperature. The result is that the target room temperature and the actual room temperature differ and the delta cannot be adjusted.

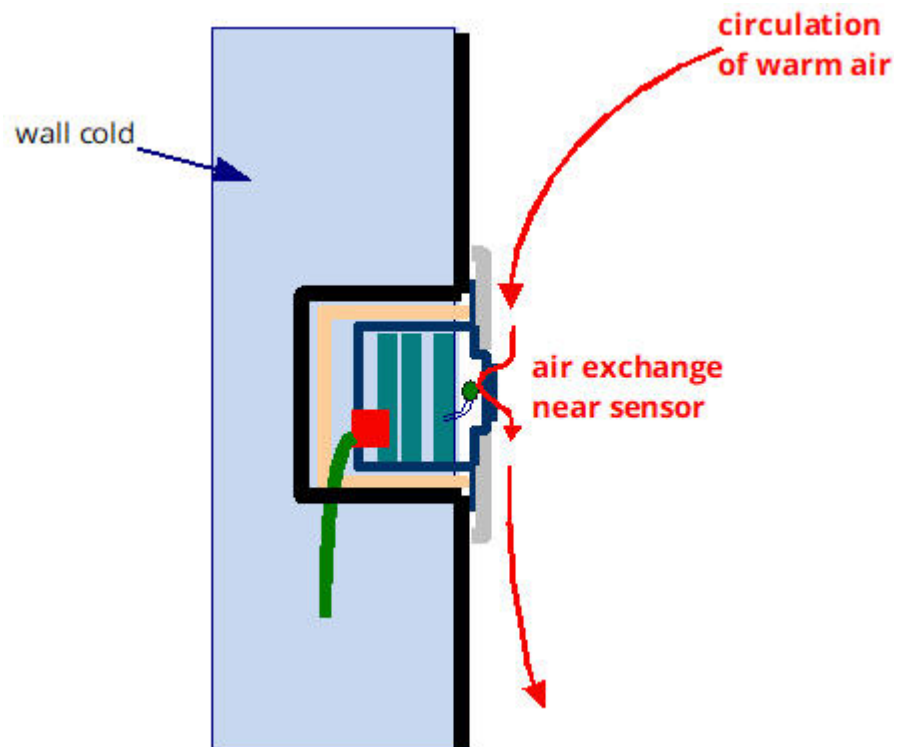

Figure 6: A cold wall leads to an incorrect adjustment of the temperature sensor in the operating device - the heat radiation component is missing

3.5. References / sources

DIN EN ISO 7730 - Ergonomics of the thermal environment - Analytical determination and interpretation of thermal comfort by calculation of the PMV and PPD indices and criteria of local thermal comfort.

4. Technical data

Power supply

Operating voltage 24V DC +/-15% or 24V AC +/- 15%

Power consumption max. 1,44 W

Network

Network type TP/FT-10 (78kbps)

Transceivertype FTT

Connections

Network 4-pin plug-in terminal connection for solid wires
Ø 0,6 – 1,0mm
four bus lines can be connected for each pin

Digital inputs 4-pole clamp connection for solid or flexible wires
(for connection to push-
buttons or potential free-
contacts) Ø max. 0,8mm

Control elements

Service push-button Sends neuron ID when pressed

Display elements

LEDs Red: Heating mode Blue: Cooling mode
Yellow: Window contact Green: Presence

Measurement range

Measurement range +5°C to +50°C
(temperature)

Measurement range 0% to 100% (without condensation)
(humidity)

Measuring tolerance

Measuring tolerance 0,5 K (at +5 °C > T > +30 °C)
(temperature)

Measuring tolerance 4% (at 20% > rH > 80%)
(humidity)

Housing

Protection	IP 20 (DIN 40050 / IEC 144)
Dimensions	70 x 70 x 41 [mm] (H x B x T)
Type/location of installation	Mounting on cavity wall sockets or flush mounting sockets according to DIN VDE 0606

Ambient conditions

Operating temperature	-5°C ... +45°C
Storage temperature	-25°C ... +55°C
Transport temperature	-25°C ... +70°C
Relative humidity	5% ... 93% (w/o condensation)
Installation height	up to 2000 m above sea level

Safety

Electrical isolation	SELV (EN 60950)
Protection class	I (DIN EN 61140, VDE 0140-1)

Standards

Device safety	Acc. EN 50 090-2-2
Immunity	Acc. EN 50 090-2-2
Certification	CE

5. Order information

Order number	Description
231 301 W	clima RO, LON Climate controller for public buildings with four digital inputs, pure white
231 301 A	clima RO, LON Climate controller for public buildings with four digital inputs, aluminium
231 311 W	clima RO, LON Climate controller for public buildings with relative humidity sensor and four digital inputs, pure white
231 311 A	clima RO, LON Climate controller for public buildings with relative humidity sensor and four digital inputs, aluminium

6. Support

The information given in this manual was carefully compiled. Should you have any further questions regarding this product, please contact:

SafeSquare GmbH

Am Graben 2-6
42477 Radevormwald
Germany

Fon: +49 (2191) 56814-0
Fax: +49 (2191) 56814-89
Email: info@safesquare.eu